

# SPECIFICATIONS:

# STONE CONVEYOR OVEN I-TSC/E



## FEATURES

- Can be stacked two units tall to double production in the same space
- 31¼" wide stone belt
- Independent digital temperature controls for top and bottom
- Digitally controlled conveyor speed for 1-20 minute cooking times
- Easy to maintain and service
- Heavy duty stainless steel exterior with high heat resistant aluminized steel interior
- Fully insulated for cooler exterior surface and consistent interior temperature
- Removable crumb tray on each end for debris collection

## ELECTRIC OVEN FEATURES

- Max temperature: 932°F (500°C)
- Stainless steel sheathed heating elements
- Remote touch screen controller

## OPTIONS

- Custom painted colour
- Extension tray at belt exit
- Automatic loading belt
- Stainless steel stand with locking casters

Size	90 second high temp napoletana	2.5 minute bake thin crust	4 minute bake New York style
	I-TSC/E	I-TSC/E	I-TSC/E
10"	520	312	195
12"	320	192	120
14"	280	168	105
16"		96	60
18"		84	53
20"		72	45
22"		60	38

# SPECIFICATIONS: STONE CONVEYOR OVEN I-TSC/E

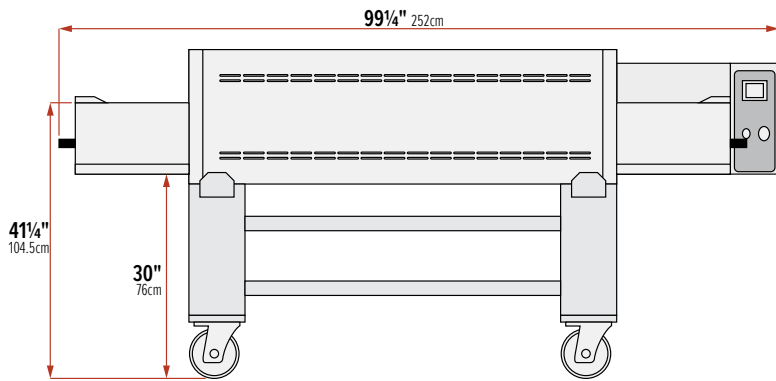

**SIDE**

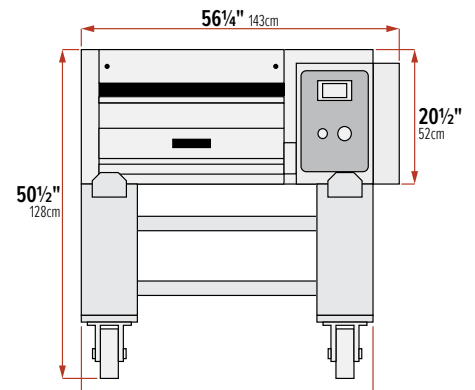

**FRONT**

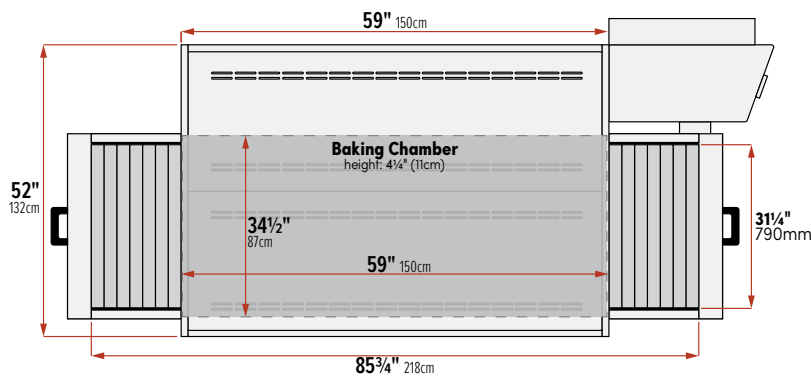

**TOP**

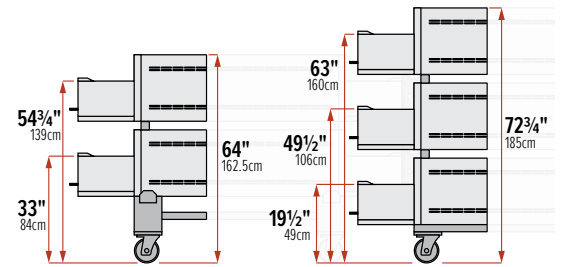

**STACKED HEIGHT**

## Electrical

Model	Power	Voltage	Amps	Phase	Plug/Cable
I-TSC/E	35KW	208-240 (60amp)	98	3	Not Supplied

Each deck is independent and uses it's own power supply

## Baking Chamber Dimensions

Model	Dimensions (Inch)			Dimensions (cm)			Conveyor Length		Conveyor Width	
	W	D	H	W	D	H	Inch	cm	Inch	cm
I-TSC/E	34 1/2	59	4 1/4	87	15	11	85 3/4	218	31 1/4	790

## Exterior Dimensions

Model	Dimensions (Inch)			Dimensions (cm)			Weight	
	W	D	H	W	D	H	Lb	Kg
I-TSC/E	56 1/4	99 1/4	20 1/2	143	252	52	925	420

Dimensions not including stand

## Shipping

Model	Dimensions (Inch)			Dimensions (cm)			Weight	
	W	D	H	W	D	H	Lb	Kg
I-TSC/E	59 7/8	103 1/4	28 1/4	152	262	72	1213	550

Stand's are packaged unassembled in the oven crate.  
Each deck is shipped in its own crate for multi deck ovens



The manufacturer reserves the right to modify the technical data and models without previous notice.

815 Alness St. Toronto Ont. M3J 2H8 Canada  
T: 647.577.3477 - F: 647.977.9214 - info@italiana.ca - www.italiana.ca