



IMMERSION BLENDER XM-12 120/50-60/1

Compact immersion blender. 0.33 Hp.



P/N. 3030740



- ✓ Ideal for mise-en-place and support in service.
- ✓ Designed to work with maximum comfort in recipients of up to 10 litres of capacity.
- ✓ In option: shorter MA-11 mixarm.

Maximum comfort for the user

- ✓ Compact design: logical and manageable size.
- ✓ Ergo-design & bi-mat-grip: The external casing, in two materials, allows an ergonomic hold with an anti-slip grip and the handle features optimum inclination to minimise fatigue.
- ✓ Click-on-arm: detachable arm with quick and safe locking.
- ✓ Hood designed to avoid splashes during work.
- ✓ Intuitive use: very simple operation. Includes warning light when the machine is connected to the mains.

Designed to last

- ✓ Professional performance: it is capable of carrying out prolonged work without overheating.
- ✓ Life-plus: equipped with a motor which has passed all of the most demanding usage tests.
- ✓ Studied geometry: casing designed to avoid rolling and falling.
- ✓ Easy to clean: the arm can be washed under the tap or in the dishwasher.
- ✓ Approved by NSF: guaranteed safety and hygiene.

INCLUDES

- ✓ Variable speed motor block.
- ✓ MA-12 mixer arm.

ACCESSORIES

- Mixer arms MA-10



SALES DESCRIPTION

The most delicate preparations, airy blendings, smooth purees with no need of add-on tools.

Designed for continuous use.

Ideal for mise en place.

Maximum comfort of use in recipients of up to 10.6qt.

All-in-one

- ✓ Versatility without add-on tools.
- ✓ Tri-blade, professional, made of tempered steel and equipped with a long lasting cutting edge.
- ✓ Vario-speed: adjustable speed.



sammic | www.sammic.us
Food Service Equipment Manufacturer

usa@sammic.com
1225 Hartrey Avenue
60202-1056 Evanston, IL

phone +1 (224) 307-2232
toll free +1 844 275 3848



Project	Date
Item	Qty
Approved	

product sheet
updated 09/02/20

DYNAMIC PREPARATION
COMMERCIAL HAND BLENDERS - XM RANGE



IMMERSION BLENDER XM-12 120/50-60/1

Compact immersion blender. 0.33 Hp.



SPECIFICATIONS

Total loading: 0.33 Hp
 Maximum recipient capacity: 10.6 qt.
 Motor speed: 1500 - 15000 rpm
 Blade diameter: 1.75 "
 Blade guard diameter: 2.56 "
 Electrical supply: 120 V / 50-60 Hz / 1 ~
 (1.5 A)

Length

Liquidising arm length: 8.8 "
 Total length: 17.6 "

Net weight: 3.1 lbs.
 Noise level (1m.): <80 dB(A)

Crated dimensions

19.5 x 3.1 x 7.1 "
 Gross weight: 4.0 lbs.

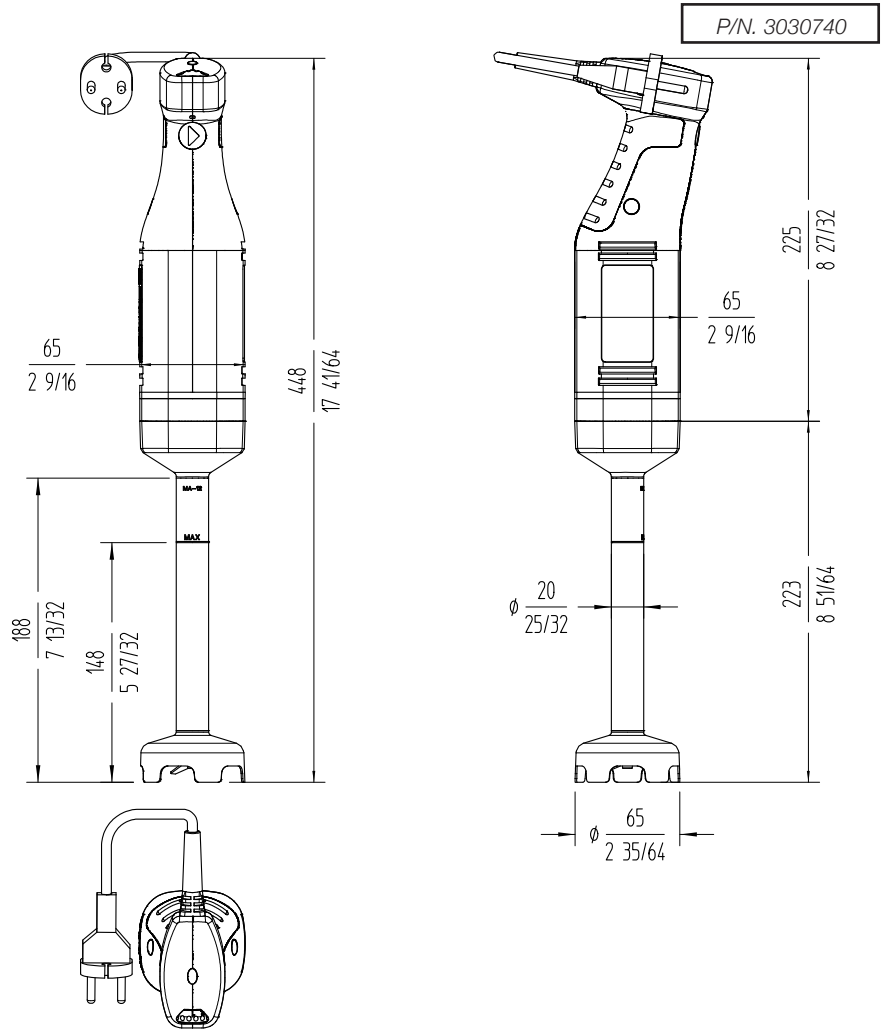

DYNAMIC PREPARATION
COMMERCIAL HAND BLENDERS - XM RANGE

sammic | www.sammic.us
 Food Service Equipment Manufacturer

usa@sammic.com phone +1 (224) 307-2232
 1225 Hartrey Avenue toll free +1 844 275 3848
 60202-1056 Evanston, IL



Project	Date
Item	Qty
Approved	

product sheet
updated 09/02/20